

TOP ENTRY BALL VALVES

Materials

BODY MATERIAL:

Body Material Code:	A	B	C	F	H	J	K	L
Description	Alloy 20	CF3M SS	Carbon Steel	Inconel (625)	Hastelloy C	Duplex (2205)	Super Duplex (2507)	LCC Carbon Steel
Body (all types)	ASTM A351 CN7M	ASTM A351 CF3M	ASTM A216 WCB	ASTM A494 CW6MC	ASTM A494 CW12MW	ASTM A995 CD3MN	ASTM A995 CD3MWCuN	ASTM A352 LCC
Bonnet								
Packing Gland	ASTM A276 Type 316 Stainless Steel							
Gland Plate	316 Stainless Steel							
Gland Plate Bolts	ASTM A193 Grade B8							
Stop	ASTM A276 Type 304							
Stop Bolts	300 Stainless Steel							
Lockplate	302 or 304 Stainless Steel							
Lever Assembly (1/2" - 2")	304 SS w/Vinyl Grip							
Lever Stem Nut (1/2" - 2")	300 Series Stainless Steel							
Lever Assembly (3" - 8")	316 SS Adapter with Stainless Pipe ¹							
Adapter Screw (3" - 8")	300 Series Stainless Steel							
Stem Screw (3" - 8")	300 Series Stainless Steel							
External Grounding Spring	Stainless Steel							
Body Joint Studs	ASTM A193-B8M		ASTM A193-B7			ASTM A193-B8M		
Body Joint Nuts	ASTM A194-Gr.8		ASTM A194-2H			ASTM A194-Gr.8		

NOTE 1: Carbon Steel valves have galvanized pipe handles

Body Material Code:	M	N	P	R	S	T	Y
Description	M35-1 (Monel)	Nickel (200)	Carbon	AL-6XN	Stainless Steel	Titanium	Hastelloy B
Body (Flanged ends)	ASTM A494 M35-1	ASTM A494 CZ100	ASTM A217 C12	ASTM A351 CN3MN AL-6XN	ASTM A351-CF8M	ASTM B367 C3	ASTM A494 N12MV
Body (Buttweld, Socket weld, and screwed ends)					ASTM A351-CF3M		
Bonnet					ASTM A351-CF8M		
Packing Gland	ASTM A276 Type 316 Stainless Steel						
Gland Plate	316 Stainless Steel						
Gland Plate Bolts	ASTM A193 Grade B8						
Stop	ASTM A276 Type 304						
Stop Bolts	300 Stainless Steel						
Lockplate	302 or 304 Stainless Steel						
Lever Assembly (1/2" - 2")	304 SS w/Vinyl Grip						
Lever Stem Nut (1/2" - 2")	300 Series Stainless Steel						
Lever Assembly (3" - 8")	316 SS Adapter with Stainless Pipe						
Adapter Screw (3" - 8")	300 Series Stainless Steel						
Stem Screw (3" - 8")	300 Series Stainless Steel						
External Grounding Spring	Stainless Steel						
Body Joint Studs	ASTM A193-B8M						
Body Joint Nuts	ASTM A194-Gr.8						

TRIM (INTERNAL) MATERIAL:

Trim Material Code:	A	B	D	E	F	H	J	K
Description	Alloy 20	316L SS	Hastelloy C Stem, M35-1 Ball	410 SS	Inconel (625)	Hastelloy C	Duplex (2205)	Super Duplex (2507)
Ball	ASTM A351-CN7M or ASTM B473-CB-3	ASTM A351-CF3M or ASTM A276-316L	ASTM A494-M35-1 or ASTM B164-K400 N04400	ASTM A276 -410	ASTM B446 N06625 or ASTM A494 GR.CW6MC	ASTM A494-CW12MW or ASTM B574-C276	ASTM A479/A276 UNS S31803 or ASTM A995 GR. CD3MN	ASTM A479/A276 UNS S32760 or ASTM A995 GR. CD3MWCuN
Stem	ASTM B473-CB-3 N08020	ASTM A276-316L	ASTM B574-C276	ASTM A276 -410 COND.A	ASTM B446 N06625	ASTM B574-C276	ASTM A479/A276 S31803	ASTM A479/A276 S32760
Seat Ring(s) (from bar, tube or pipe depending on availability)	ASTM B473-CB-3 N08020	ASTM A276-316L	ASTM B574-C276	ASTM A269-316 or A276-316/316L or A312-316	ASTM B446 N06625	ASTM B574-C276	ASTM A479/A276 S31803	ASTM A479/A276 S32760
Internal Spring (M seat)	Inconel X-750	ASTM A312-Type 316	ASTM B574 Hastelloy C	ASTM A312-Type 316	Inconel X-750	ASTM B574 Hastelloy C	Inconel X-750	
Internal Spring (4, 5, 6, 8, 9, B, C, D, G, H, L, N, or U seats)	Inconel X-750			Inconel X-750				

TOP ENTRY BALL VALVES

Materials

TRIM (INTERNAL) MATERIAL (CONT'D):

Trim Material Code:	M	N	R	S	T	Y
Description	M35-1	Nickel (200)	AL-6XN	Stainless Steel	Titanium	Hastelloy B
Ball	ASTM A494-M35-1 or ASTM B164-K400 N04400	ASTM A494-CZ100 or ASTM B160-200	ASTM B691 N08367 or ASTM A351 CN3MN	ASTM A351-CF8M or ASTM A276- 316/316L A312-316	ASTM B367-Gr. C3 or ASTM B348-Gr. 5	ASTM B335 N10665 or ASTM A494-N-12MV
Stem	ASTM B164-K400 N04400	ASTM B160-200	ASTM B691 N08367	ASTM A269-316 ASTM A276- 316/316L or ASTM A312-316	ASTM B348-Gr. 5	ASTM B335 N10665
Seat Ring(s) (from bar, tube or pipe depending on availability)	ASTM B164-K400	ASTM B160-200	ASTM B691 N08367	ASTM A269-316 ASTM A276- 316/316L or ASTM A312-316	ASTM B348-Gr.2	ASTM B335 N10665
Internal Spring (M seat)	Inconel X-750		Inconel X-750	ASTM A312- Type 316	ASTM B348-Gr.5	Hastelloy B-2
Internal Spring (4, 5, 6, 8, 9, B, C, D, G, H, L, N, or U seats)			Inconel X-750			

SEAT & SEALS MATERIAL:

Seat Code:	4	5	6	8	9
Seat	Carbon Graphite	55% Bronze, 5% Moly Filled PTFE	UHMWPE	Unfilled PEEK	CERAMIC (Seats & Ball)
Seat O-ring	Not Applicable				
Stem Packing	Flexible Graphite				
Bonnet Gasket	Spiral Wound Flexible Graphite				
Stem Bearing	Nitronic® 60	PEEK	UHMWPE	PEEK	Nitronic® 60
Default Suffix	24			24	

Seat Code:	B	C	D	G	H
Seat	Carbon Reinforced PEEK	PFA	60% Stainless Filled PTFE	PCTFE	High Temp. Graphite
Seat O-ring	Not Applicable				
Stem Packing	Flexible Graphite			RPTFE	Flexible Graphite
Bonnet Gasket	Spiral Wound Flexible Graphite			RPTFE (150/300) Spiral Wound PTFE (600)	Spiral Wound Flexible Graphite
Stem Bearing	PEEK	PEEK	PEEK	PEEK	Nitronic® 60
Default Suffix	24			01	24

Seat Code:	L	M	N	U
Seat	API 607 Multiseal Fire Seat	TFM Multiseal	Nylon	UHMWPE
Seat O-ring	Multiseal Ring	N/A	Nylon	Not Applicable
Stem Packing	Flexible Graphite	PTFE	Flexible Graphite	
Bonnet Gasket	Spiral Wound Flexible Graphite	RPTFE (150/300) Spiral Wound PTFE (600)	Spiral Wound Flexible Graphite	
Stem Bearing	PEEK	PEEK	Nylon	UHMWPE
Default Suffix	24	01	24	



For additional information, submittal sheets and manuals, visit www.apollovalves.com

Customer Service (704) 841-6000

REV. 8/30/13

TOP ENTRY BALL VALVES

Seat Materials and Seat Designs

SEAT CODE "G" (PCTFE)

Polychlorotrifluoroethylene is typically used in cryogenic applications. High resistance to inorganic corrosive liquids, including oxidizing acids. Resistant to most organic solvents except some highly halogenated and aromatic materials. (Figure 1) See Pressure-Temperature Chart 2, page 10.

SEAT CODE "L" (TFM MULTISEAL)

API-607 fire-safe design.

This seat design has been successfully tested to the requirements of API 607. The Multiseal seat is fully confined by a metallic seat holder which provides a secondary seal in the event of the loss of the primary TFM seal during a fire. The torque characteristics will be the same as in the #M seats. (Figure 3) See Pressure-Temperature Chart 1, page 10.

SEAT CODE "M" (TFM MULTISEAL)

Apollo's Multiseal is a modified PolyTetraFluoroEthylene (PTFE) that maintains the exceptional chemical resistance and heat resistance properties of conventional PTFE. (Figure 1) See Pressure-Temperature Chart 1, page 10.

SEAT CODE "C" (PFA)

Perfluoroalkoxy seats withstand the effects of polymeric monomers such as butadiene and styrene. (Figure 2) See Pressure-Temperature Chart 1, page 10.

SEAT CODE "5" (55% BRONZE / 5% MOLY BRTFE)

Specifically intended for steam applications. Also applicable to abrasive and throttling applications because of the heavy loading of reinforcing materials and the presence of the inner ring. However, chemical compatibility may be a limiting factor in the application of this seat. (Figure 2) See Pressure-Temperature Chart 3, page 11.

SEAT CODE "D" (60% STAINLESS STEEL SRTFE)

Intended for abrasive and throttling applications because of the heavy loading of reinforcing materials and the completely confined seat. (Figure 2) See Pressure-Temperature Chart 1, page 10.

SEAT CODE "6" (UHMWPE)

Ultra High Molecular Weight Polyethylene offers good abrasion resistance making it suitable for use in high solids or slurry applications. These seats are completely confined by a metallic seat holder enhancing their performance in abrasive services. This seat is frequently specified in services where fluorine off-gassing in even the slightest amounts is objectionable. Examples of these services are food, tobacco processing, and nuclear services. (Figure 2) See Pressure-Temperature Chart 4, page 11.

Figure 1
Seat Design 1

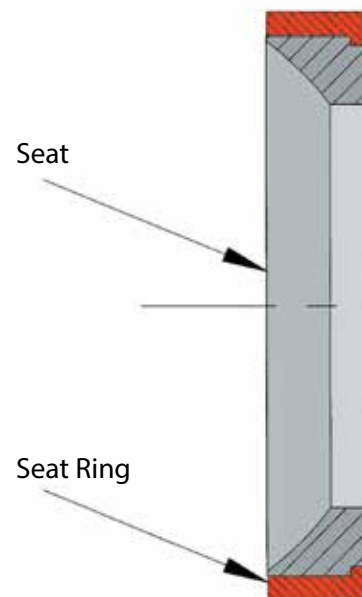
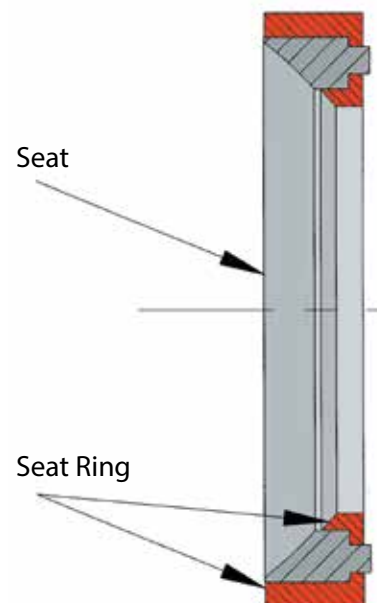

Figure 2
Seat Design 2



TOP ENTRY BALL VALVES

Seat Materials and Seat Designs

Figure 3
Seat Design 3

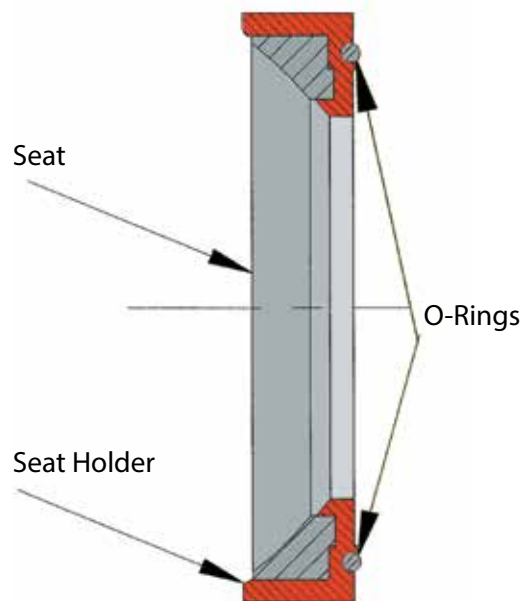
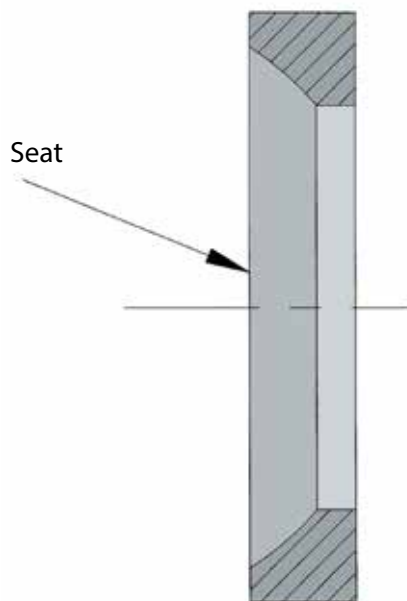

Figure 4
Seat Design 4



SEAT CODE "U" (UHMWPE)

Exhibits the same characteristics as the #6 seat with the exception that it utilizes the inner seat ring to enhance performance in abrasive services. UHMWPE should be used with caution in the presence of solvents, and the operating torque can be expected to be 30% higher than that of the PTFE based seat materials. (Figure 1) See Pressure-Temperature Chart 4, page 11.

SEAT CODE "8" (PEEK)

PEEK (PolyEtherEtherKetone) offers a high strength alternative to RPTFE, resistant to creep and cold flow. This seat offers good abrasion resistance. Higher in cost, this material offers similar chemical resistance to PTFE but should be checked on application. Operating torque tend to be 40% higher than RPTFE. Ball stop recommended. (Figure 2) See Pressure-Temperature Chart 5, page 12.

SEAT CODE "B" (CARBON REINFORCED PEEK)

Carbon Reinforced PEEK provides improved abrasion resistance when compared to the unfilled variety. Higher in cost, this material offers a broader temperature range than PTFE with similar chemical resistance but should be checked on application. Operating torque tends to be 40% higher than PTFE. Ball stop recommended. (Figure 2) See Pressure-Temperature Chart 5, page 12.

SEAT CODE "4" (CARBON GRAPHITE)

Designed for high temperature applications. A ball stop is required in applications above 500°F. Maximum service temperature is limited to 750°F in oxidizing applications. This seat like all rigid seat materials does not necessarily provide "bubble tight" shut-off. Most test standards have allowable leakage rates or list "classes" of shut-off for this type of seat. Be aware of the system design requirements when specifying this or any rigid seat. Ball stop recommended. (Figure 1) See Pressure-Temperature Chart 6, page 12.

SEAT CODE "H" (HIGH TEMPERATURE GRAPHITE)

Designed for very high temperature applications. A ball stop is required in applications above 500°F. Maximum service temperature is limited to 1000°F. This seat like other rigid seat materials does not provide "bubble tight" shut-off. This seat is not as abrasion resistant as the #4 version. Be aware of the system design requirements when specifying this or any rigid seat. Ball stop recommended. (Figure 1) See Pressure-Temperature Chart 6, page 12.

SEAT CODE "9" (CERAMIC)

Working in conjunction with a ceramic ball, this seat outperforms all other materials in throttling and abrasive applications. It possesses excellent chemical resistance. A ball stop is recommended for all applications. This seat like all rigid seat materials does not necessarily provide "bubble tight" shut-off. Most test standards have allowable leakage rates or list "classes" of shut-off for this type of seat. Be aware of the system design requirements when specifying this or any rigid seat. (Figure 4) See Pressure-Temperature Chart 7, page 13.

TOP ENTRY BALL VALVES

Pressure-Temperature Ratings

Temp °F	Valve Body Rating ¹ – psi								
	ASTM A216 Grade WCB ² Carbon Steel			ASTM A351 Grade CF8M ³ (close wrought equivalent is 316 SS)			ASTM A351 Grade CF3M (close wrought equivalent is 316L SS)		
	Class 150	Class 300	Class 600	Class 150 ⁴	Class 300	Class 600	Class 150	Class 300	Class 600
-20 to 100	285	740	1480	275	720	1440	230	600	1200
200 F	260	680	1360	235	620	1240	195	510	1020
300 F	230	655	1310	215	560	1120	175	455	910
400 F	200	635	1265	195	515	1025	160	420	840
500 F	170	605	1205	170	480	955	150	395	785
600 F	140	570	1135	140	450	900	140	370	745
650 F	125	550	1100	125	440	885	125	365	730
700 F	110	530	1060	110	435	870	110	360	720
750 F	95	505	1015	95	425	855	110	355	705
800 F	80	410	825	80	420	845	80	345	690
850 F	65	320	640	65	420	835			
900 F	50	230	460	50	415	830			
950 F	35	135	275	35	385	775			
1000 F	20	85	170	20	365	725			
1050 F				20	360	720			
1100 F				20	305	610			
1150 F				20	235	475			
1200 F				20	185	370			
1250 F				20	145	295			
1300 F				20	115	235			
1350 F				20	95	190			
1400 F				20	75	150			
1450 F				20	60	115			
1500 F				15	40	85			

Temp °C	Valve Body Rating ¹ – bar								
	ASTM A216 Grade WCB ² Carbon Steel			ASTM A351 Grade CF8M ³ (close wrought equivalent is 316 SS)			ASTM A351 Grade CF3M (close wrought equivalent is 316L SS)		
	Class 150	Class 300	Class 600	Class 150 ⁴	Class 300	Class 600	Class 150	Class 300	Class 600
-29 to 38 C	19.6 bar	51.1 bar	102.1 bar	19.0 bar	49.6 bar	99.3 bar	15.9 bar	41.4 bar	82.7 bar
50 C	19.2 bar	50.1 bar	100.2 bar	18.4 bar	48.1 bar	96.2 bar	15.3 bar	40.0 bar	80.0 bar
100 C	17.7 bar	46.6 bar	93.2 bar	16.2 bar	42.2 bar	84.4 bar	13.3 bar	34.8 bar	69.6 bar
150 C	15.8 bar	45.1 bar	90.2 bar	14.8 bar	38.5 bar	77.0 bar	12.0 bar	31.4 bar	62.8 bar
200 C	13.8 bar	43.8 bar	87.6 bar	13.7 bar	35.7 bar	71.3 bar	11.2 bar	29.2 bar	58.3 bar
250 C	12.1 bar	41.9 bar	83.9 bar	12.1 bar	33.4 bar	66.8 bar	10.5 bar	27.5 bar	54.9 bar
300 C	10.2 bar	39.8 bar	79.6 bar	10.2 bar	31.6 bar	63.2 bar	10.0 bar	26.1 bar	52.1 bar
325 C	9.3 bar	38.7 bar	77.4 bar	9.3 bar	30.9 bar	61.8 bar	9.3 bar	25.5 bar	51.0 bar
350 C	8.4 bar	37.6 bar	75.1 bar	8.4 bar	30.3 bar	60.7 bar	8.4 bar	25.1 bar	50.1 bar
375 C	7.4 bar	36.4 bar	72.7 bar	7.4 bar	29.9 bar	59.8 bar	7.4 bar	24.8 bar	49.5 bar
400 C	6.5 bar	34.7 bar	69.4 bar	6.5 bar	29.4 bar	58.9 bar	6.5 bar	24.3 bar	48.6 bar
425 C	5.5 bar	28.8 bar	57.5 bar	5.5 bar	29.1 bar	58.3 bar	5.5 bar	23.9 bar	47.7 bar
450 C	4.6 bar	23.0 bar	46.0 bar	4.6 bar	28.8 bar	57.7 bar			
475 C	3.7 bar	17.4 bar	34.9 bar	3.7 bar	28.7 bar	57.3 bar			
500 C	2.8 bar	11.8 bar	23.5 bar	2.8 bar	28.2 bar	56.5 bar			
538 C	1.4 bar	5.9 bar	11.8 bar	1.4 bar	25.2 bar	50.0 bar			
550 C				1.4 bar	25.0 bar	49.8 bar			
575 C				1.4 bar	24.0 bar	47.9 bar			
600 C				1.4 bar	19.9 bar	39.8 bar			
625 C				1.4 bar	15.8 bar	31.6 bar			
650 C				1.4 bar	12.7 bar	25.3 bar			
675 C				1.4 bar	10.3 bar	20.6 bar			
700 C				1.4 bar	8.4 bar	16.8 bar			
725 C				1.4 bar	7.0 bar	14.0 bar			
750 C				1.4 bar	5.9 bar	11.7 bar			
775 C				1.4 bar	4.6 bar	9.0 bar			
800 C				1.2 bar	3.5 bar	7.0 bar			
816 C				1.0 bar	2.8 bar	5.9 bar			

1 Ratings per ASME B16.34 - 2009

2 WCB: Upon prolonged exposure to temperatures above 800°F (425°C), the carbide phase of steel may be converted to graphite. Permissible, but not recommended for prolonged usage above 800°F (425°C)

3 CF8M: At temperatures above 1000°F (538°C), use only when the carbon content is 0.04% or higher.

4 CF8M Class 150: Flanged End valve ratings terminate at 1000°F (538°C)

TOP ENTRY BALL VALVES

Pressure-Temperature Ratings

Temp °F	Valve Body Rating ¹ – psi								
	ASTM A351 Grade CN7M (close wrought equivalent is Alloy 20)			ASTM A494 Grade CW-12MW (close wrought equivalent is Hastelloy® C)			ASTM A494 Grade M-35-1 (close wrought equivalent is Monel®)		
	Class 150	Class 300	Class 600	Class 150	Class 300	Class 600	Class 150	Class 300	Class 600
-20 to 100	230	600	1200	230	600	1200	230	600	1200
200 F	200	520	1035	210	550	1105	200	525	1050
300 F	180	465	930	200	520	1040	190	490	980
400 F	160	420	845	190	490	980	180	475	945
500 F	150	390	780	170	465	925	170	475	945
600 F	140	360	720	140	440	880	140	475	945
650 F				125	430	860	125	475	945
700 F				110	420	835	110	470	940
750 F				95	410	820	95	465	930
800 F				80	400	800	80	460	915
850 F				65	395	785	65	375	755
900 F				50	385	775	50	275	550
950 F				35	380	760			
1000 F				20	365	725			

1 Ratings per ASME B16.34 - 2009

Temp °C	Valve Body Rating ¹ – bar								
	ASTM A351 Grade CN7M (close wrought equivalent is Alloy 20)			ASTM A494 Grade CW-12MW (close wrought equivalent is Hastelloy® C)			ASTM A494 Grade M-35-1 (close wrought equivalent is Monel®)		
	Class 150	Class 300	Class 600	Class 150	Class 300	Class 600	Class 150	Class 300	Class 600
-29 to 38 C	15.9 bar	41.4 bar	82.7 bar	15.9 bar	41.4 bar	82.7 bar	15.9 bar	41.4 bar	82.7 bar
50 C	15.4 bar	40.1 bar	80.3 bar	15.6 bar	40.6 bar	81.3 bar	15.4 bar	40.2 bar	80.5 bar
100 C	13.5 bar	35.3 bar	70.6 bar	14.5 bar	37.8 bar	75.6 bar	13.8 bar	35.9 bar	71.9 bar
150 C	12.3 bar	32.0 bar	64.1 bar	13.7 bar	35.9 bar	71.7 bar	12.9 bar	33.7 bar	67.5 bar
200 C	11.3 bar	29.4 bar	58.7 bar	13.0 bar	33.9 bar	67.9 bar	12.5 bar	32.7 bar	65.4 bar
250 C	10.4 bar	27.2 bar	54.4 bar	12.1 bar	32.3 bar	64.5 bar	12.1 bar	32.6 bar	65.2 bar
300 C	9.7 bar	25.4 bar	50.8 bar	10.2 bar	30.7 bar	61.5 bar	10.2 bar	32.6 bar	65.2 bar
325 C	9.3 bar	24.4 bar	48.8 bar	9.3 bar	30.1 bar	60.1 bar	9.3 bar	32.6 bar	65.2 bar
350 C				8.4 bar	29.4 bar	58.8 bar	8.4 bar	32.6 bar	65.1 bar
375 C				7.4 bar	28.7 bar	57.4 bar	7.4 bar	32.4 bar	64.8 bar
400 C				6.5 bar	28.3 bar	56.5 bar	6.5 bar	32.1 bar	64.2 bar
425 C				5.5 bar	27.7 bar	55.3 bar	5.5 bar	31.6 bar	63.3 bar
450 C				4.6 bar	27.2 bar	54.4 bar	4.6 bar	26.9 bar	53.8 bar
475 C				3.7 bar	26.8 bar	53.5 bar	3.7 bar	20.8 bar	41.5 bar
500 C				2.8 bar	26.3 bar	52.6 bar			
538 C				1.4 bar	25.2 bar	50.0 bar			

1 Ratings per ASME B16.34 - 2009

Contact Factory
INCONEL 625 ASTM A494-GR CW6MC
NICKEL 200 ASTM A494-CZ100
TITANIUM ASTM B367-GR C3



For additional information, submittal sheets and manuals, visit www.apollovalves.com

Customer Service (704) 841-6000

TOP ENTRY BALL VALVES

Pressure-Temperature Ratings

CHART 1

PFA, TFM, SRTFE – PRESSURE-TEMPERATURE RATINGS

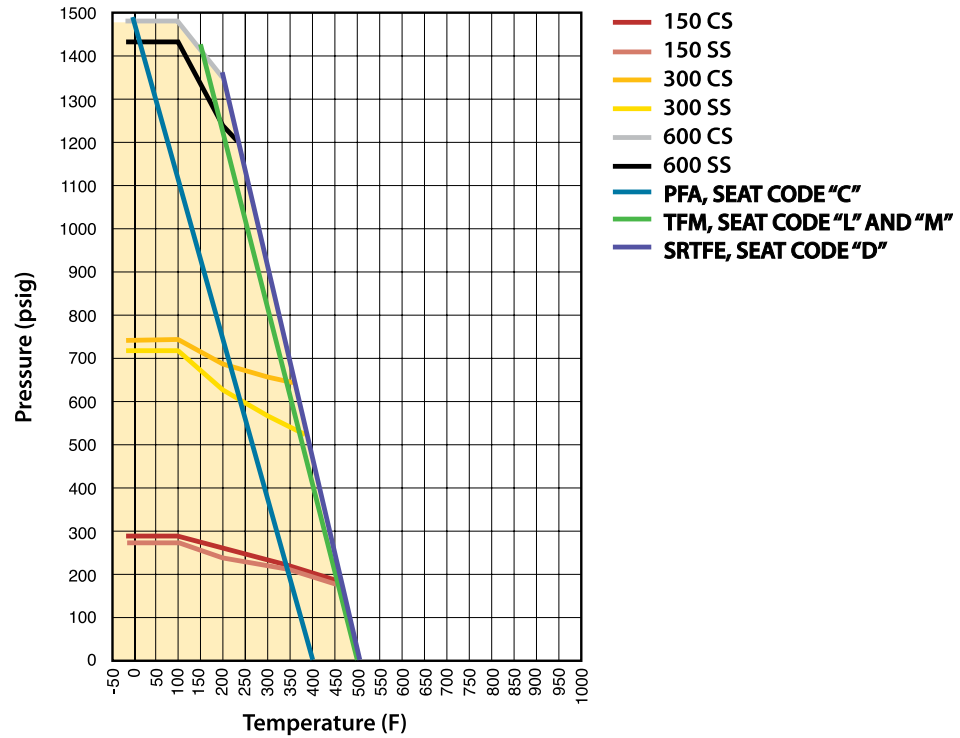
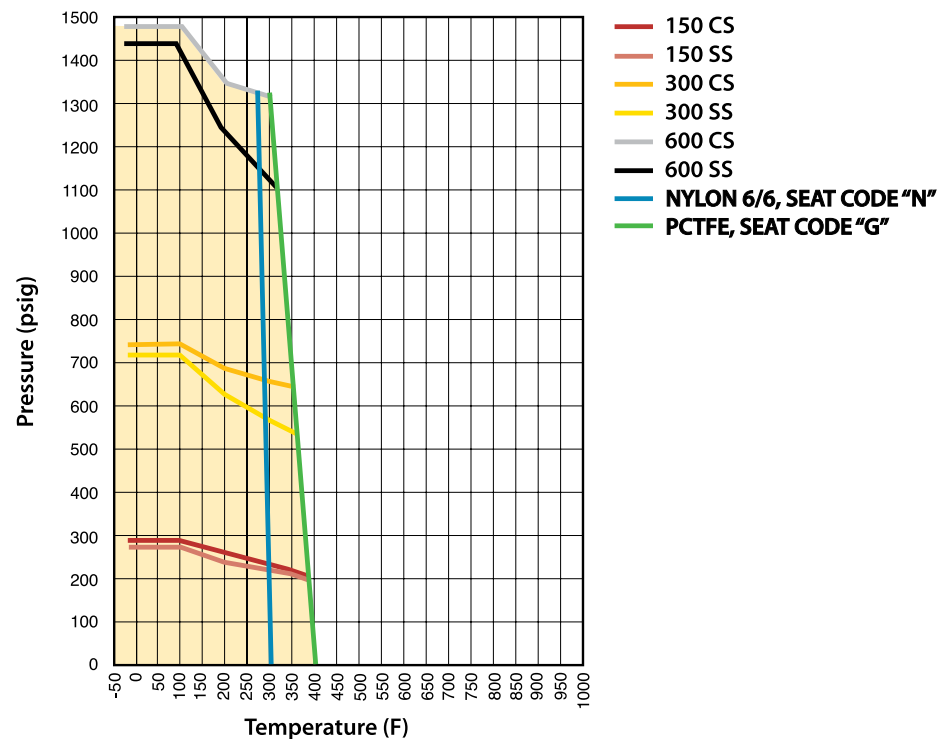

CHART 2

NYLON, PCTFE – PRESSURE-TEMPERATURE RATINGS



TOP ENTRY BALL VALVES

Pressure-Temperature Ratings

CHART 3

55% BRONZE, 5% MOLY – PRESSURE-TEMPERATURE RATINGS

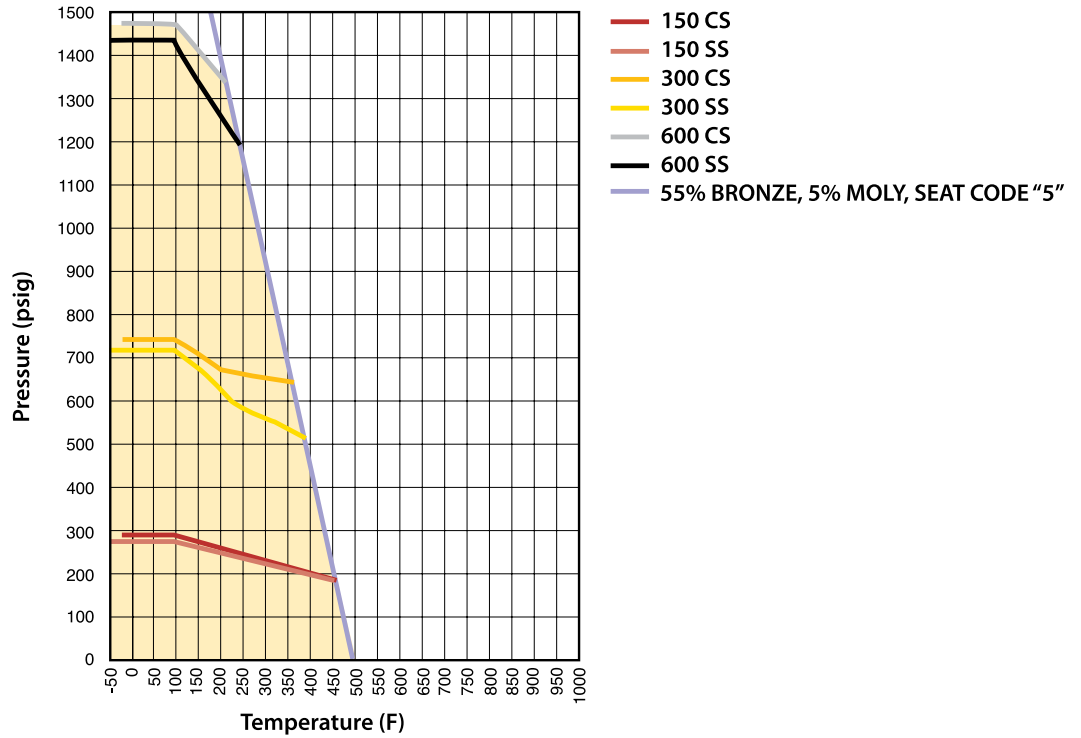
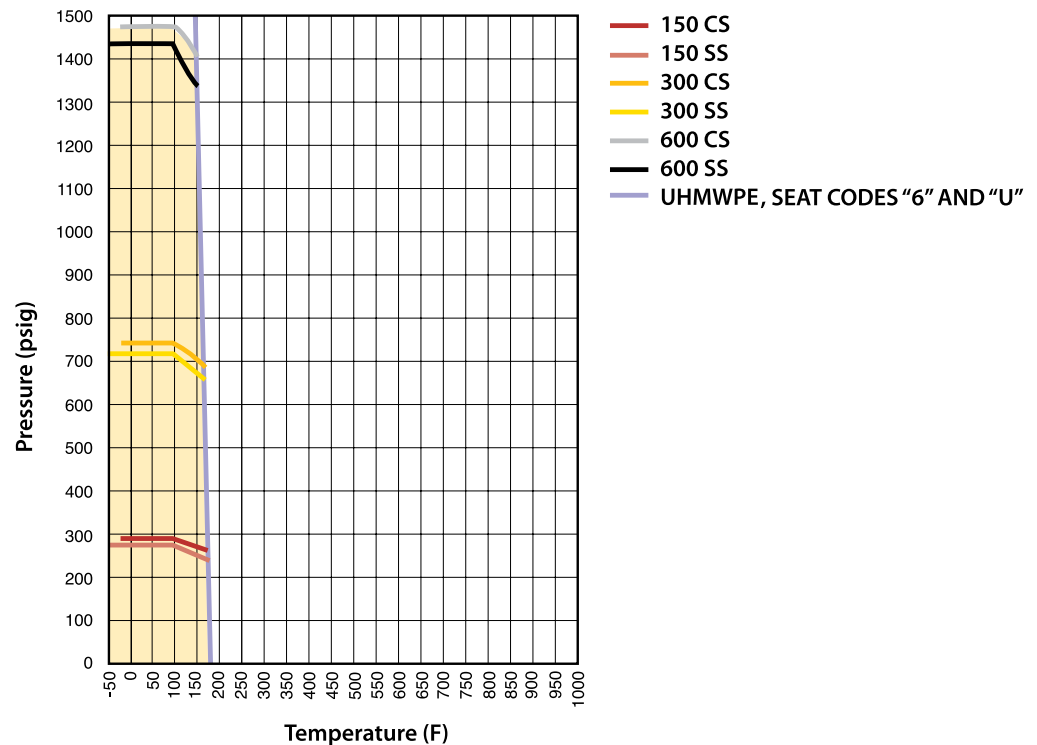

CHART 4

UHMWPE SEATS – PRESSURE-TEMPERATURE RATINGS



TOP ENTRY BALL VALVES

Pressure-Temperature Ratings

CHART 5

PEEK SEATS – PRESSURE-TEMPERATURE RATINGS

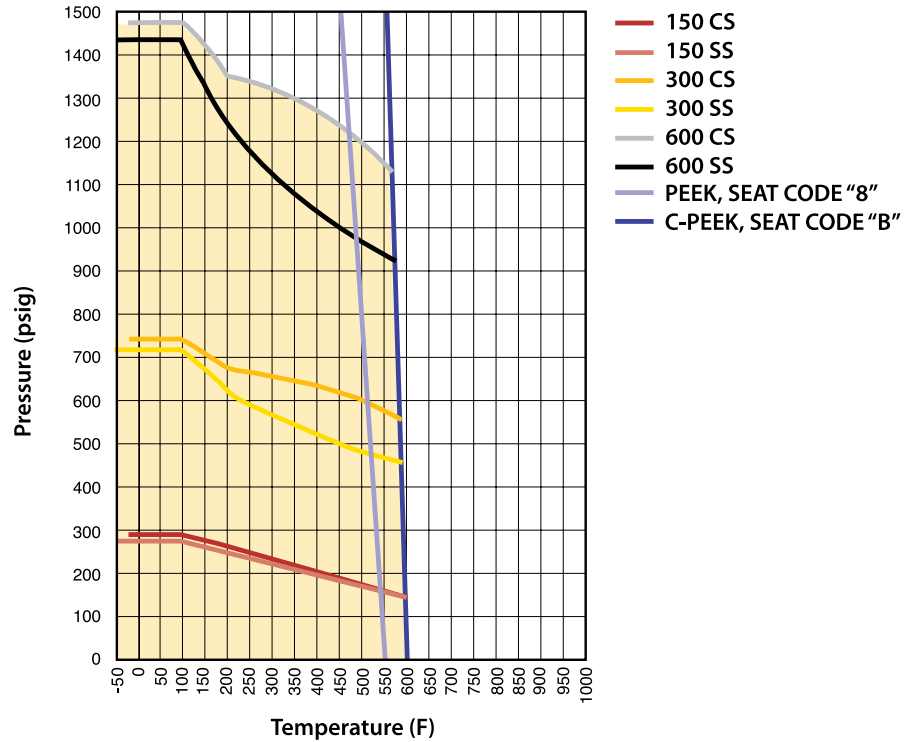
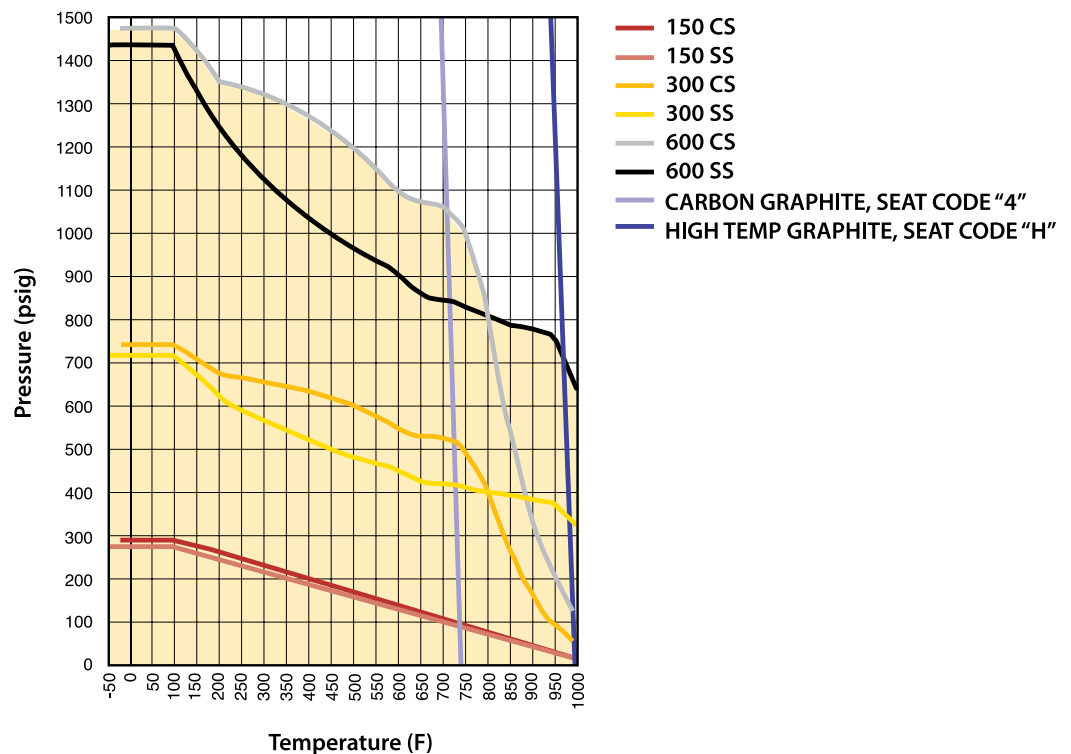

CHART 6

CARBON-GRAPHITE SEATS – PRESSURE-TEMPERATURE RATINGS



TOP ENTRY BALL VALVES

Pressure-Temperature Ratings

CHART 7

CERAMIC SEATS – PRESSURE-TEMPERATURE RATINGS

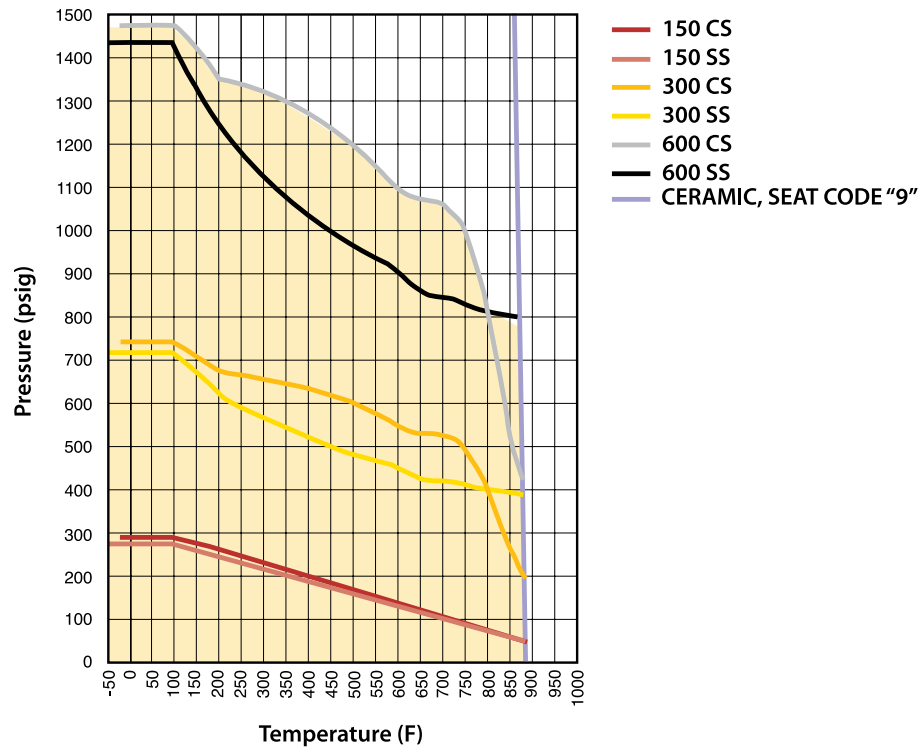
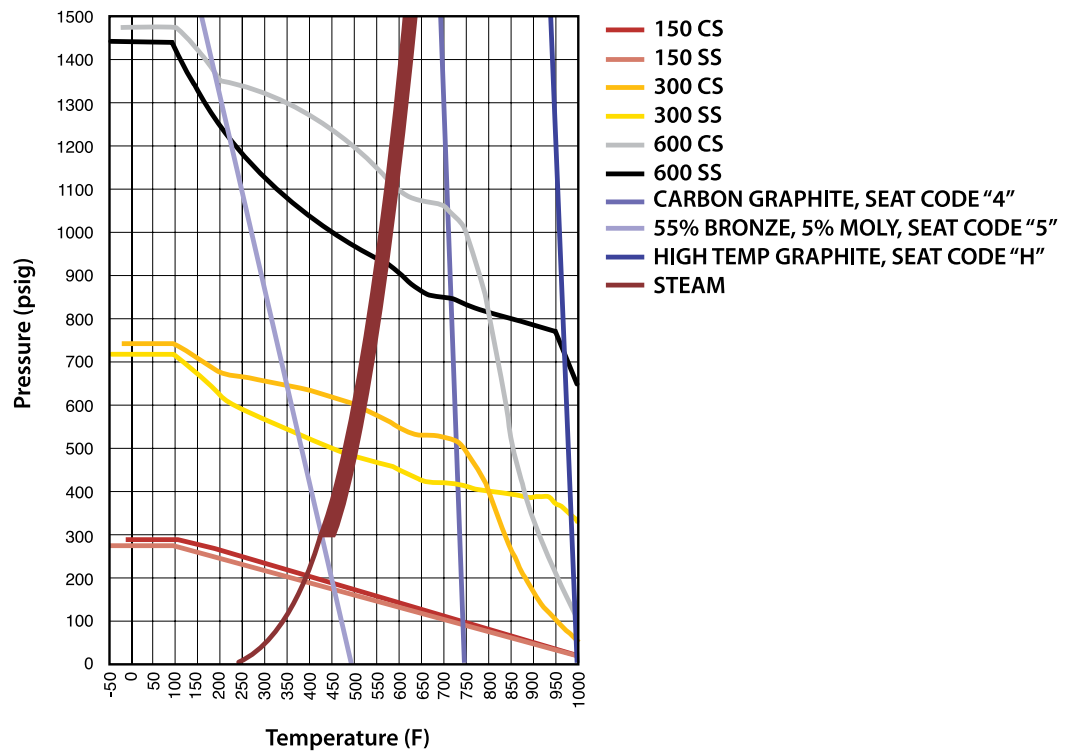

CHART 8

STEAM RATED SEATS – PRESSURE-TEMPERATURE RATINGS



TOP ENTRY BALL VALVES

ASME Class 300, Standard Port, Socket Weld

DIMENSIONS

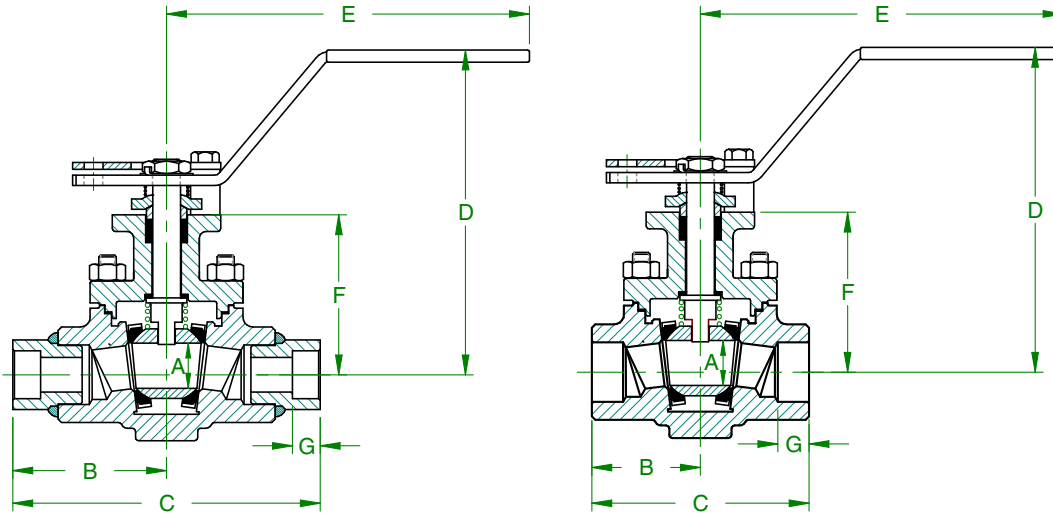

FIGURE 1

FIGURE 2

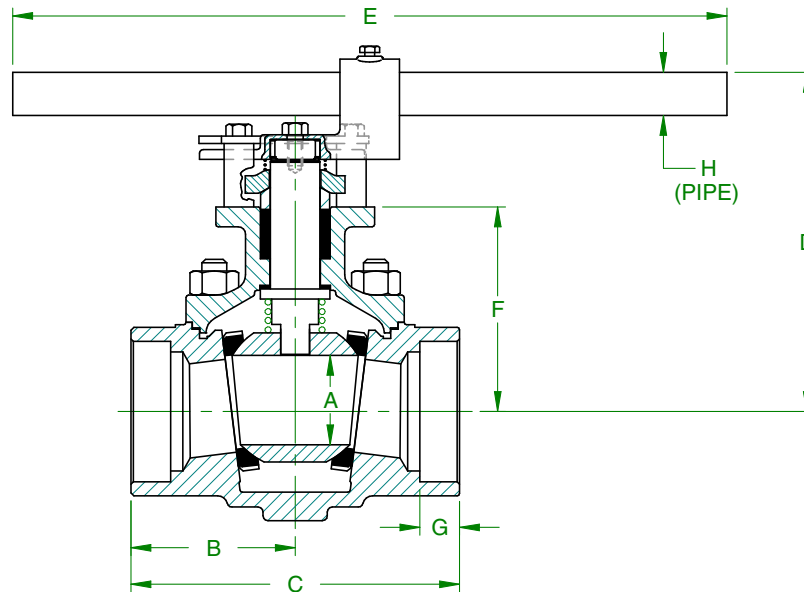

FIGURE 3

ASME CLASS 300, STANDARD PORT, SOCKET WELD Dimensions in Inches

	Size	A	B	C	D	E	F	G	H
FIGURE 1	1/4"	0.81	2.77	5.54	5.84	6.56	2.88	0.50	NA
	1/2"	0.81	2.77	5.54	5.84	6.56	2.88	0.50	NA
	3/4"	0.81	1.96	3.91	5.84	6.56	2.88	0.56	NA
FIGURE 2	1"	0.81	1.96	3.91	5.84	6.56	2.88	0.50	NA
	1.5"	1.17	2.49	4.98	5.57	6.65	3.36	0.55	NA
	2"	1.50	2.86	5.72	6.36	8.40	4.06	0.62	NA
FIG 3	3"	2.25	4.14	8.28	8.55	18.00	5.16	1.00	3/4" SCH.40

TOP ENTRY BALL VALVES

ASME Class 600, Standard Port, Socket Weld

DIMENSIONS

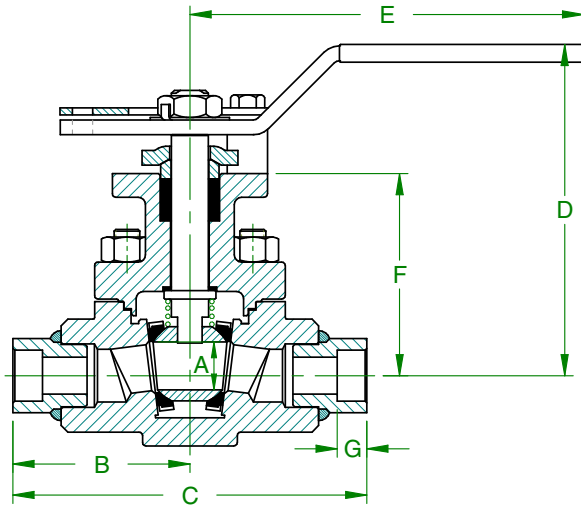

FIGURE 1

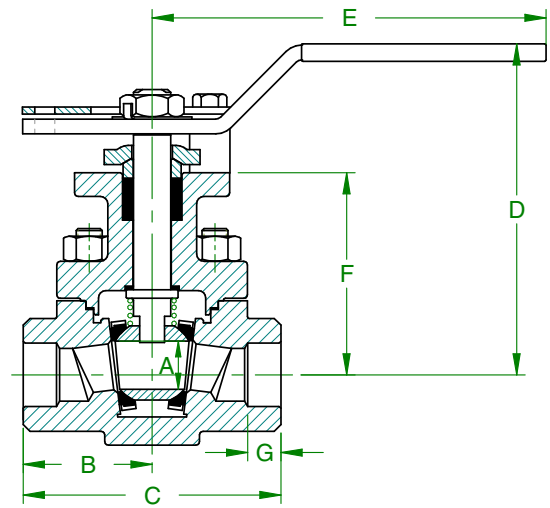

FIGURE 2

ASME CLASS 600, STANDARD PORT, SOCKET WELD Dimensions in Inches

	Size	A	B	C	D	E	F	G
FIGURE 1	1/4"	0.81	2.99	5.98	5.63	6.65	3.41	0.50
	1/2"	0.81	2.99	5.98	5.63	6.65	3.41	0.50
	3/4"	0.81	2.18	4.35	5.63	6.65	3.41	0.56
FIGURE 2	1"	0.81	2.18	4.35	5.63	6.65	3.41	0.50
	1.5"	1.17	2.62	5.23	5.98	8.40	3.68	0.55
	2"	1.50	2.99	5.98	6.57	8.40	4.27	0.62

TOP ENTRY BALL VALVES

ASME Class 300 & 600, Full Port, Socket Weld

DIMENSIONS

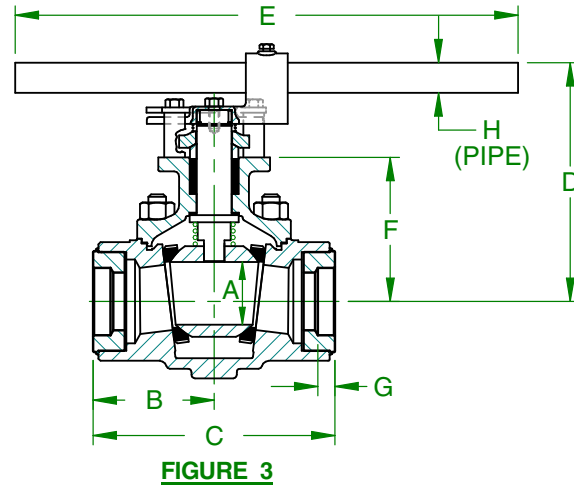
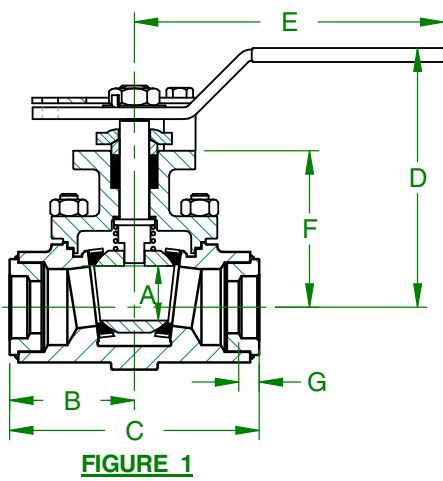

ASME CLASS 300, FULL PORT, SOCKET WELD Dimensions in Inches

	Size	A	B	C	D	E	F	G	H
FIGURE 1	1"	1.17	2.68	5.36	5.57	6.65	3.36	0.38	NA
	1.5"	1.50	3.05	6.10	6.36	8.40	4.06	0.55	NA
FIGURE 3	2"	2.25	4.34	8.67	8.55	18.00	5.16	0.62	3/4" SCH.40

ASME CLASS 600, FULL PORT, SOCKET WELD Dimensions in Inches

	Size	A	B	C	D	E	F	G
FIGURE 1	1"	1.17	2.81	5.61	5.98	8.40	3.68	0.38
	1.5"	1.50	3.18	6.36	6.57	8.40	4.27	0.55

TOP ENTRY BALL VALVES

Actuation Mounting - Standard Port, Flanged

DIMENSIONS

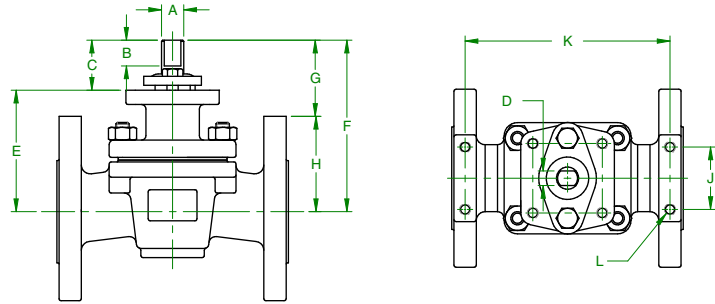

ASME CLASS 150, STANDARD PORT, FLANGED Dimensions in Inches

Size	Mtg Pad	A	B	C	D	E	F	G	H	J	K	L
1/2"	DETAIL A	0.500	0.48	1.00	0.287	2.88	3.88	NA	NA	NA	NA	NA
3/4"						2.94	3.94	1.58	2.36	1.75	4.06	5/16"-18
1"						2.97	3.97	1.29	2.46	1.75	4.43	5/16"-18
1.5"	DETAIL B	0.625	0.72	1.40	0.412	3.41	4.82	2.14	2.68	1.75	5.75	5/16"18
2"						0.750	0.80	1.57	0.477	4.24	5.81	2.51
3"	DETAIL C	1.250	0.50	1.70	0.725	5.16	6.85	2.97	3.88	3.50	7.18	3/8"-16
4"						5.29	6.98	2.35	4.63	4.00	8.19	7/16"-14
6"	DETAIL D	2.000	1.00	2.73	1.375	7.59	10.32	4.70	5.62	4.00	14.25	7/16"-14
8"						8.79	11.52	4.52	7.00	5.00	16.75	1/2"-13
10"	DETAIL E	2.490	2.25*	5.77	NA	11.63	17.40	8.40	9.00	7.00	19.75	3/4"-10
12"						13.69	19.46	NA	NA	NA	NA	NA

*Keyway length

ASME CLASS 300, STANDARD PORT, FLANGED Dimensions in Inches

Size	Mtg Pad	A	B	C	D	E	F	G	H	J	K	L
1/2"	DETAIL A	0.500	0.48	1.00	0.287	2.88	3.88	NA	NA	NA	NA	NA
3/4"						3.03	4.03	1.58	2.45	1.75	5.31	5/16"-18
1"						3.06	4.04	1.48	2.56	1.75	5.75	5/16"-18
1.5"	DETAIL B	0.625	0.72	1.40	0.412	3.47	4.88	1.58	3.30	1.75	6.63	5/16"-18
2"						0.750	0.80	1.57	0.477	4.33	5.90	2.25
3"	DETAIL C	1.250	0.50	1.70	0.725	5.16	6.85	2.60	4.25	3.50	9.88	3/8"-16
4"						5.29	6.98	1.85	5.13	4.00	10.69	7/16"-14
6"	DETAIL D	2.000	1.00	2.73	1.375	7.59	10.32	3.94	6.38	4.00	14.31	7/16"-14
8"						8.79	11.52	3.77	7.75	5.00	18.06	1/2"-13
10"	DETAIL E	2.490	2.25*	5.77	NA	11.63	17.40	8.40	9.00	7.00	20.44	3/4"-10
12"						13.69	19.46	NA	NA	NA	NA	NA

*Keyway length

ASME CLASS 600, STANDARD PORT, FLANGED Dimensions in Inches

Size	Mtg Pad	A	B	C	D	E	F	G	H	J	K	L
1/2"	DETAIL B	0.625	0.72	1.40	0.412	3.41	4.82	NA	NA	NA	NA	NA
3/4"						3.65	5.06	2.62	2.44	2.38	6.32	3/8"-16
1"						3.71	5.11	2.55	2.56	2.38	7.25	3/8"-16
1.5"						3.91	5.48	2.23	3.25	2.75	8.06	1/2"-13
2"						4.70	6.27	2.89	3.38	3.50	9.94	1/2"-13
3"	DETAIL C	1.250	0.50	1.70	0.725	5.38	7.08	2.83	4.25	4.75	12.25	1/2"-13
4"						5.69	7.38	1.88	5.50	5.50	15.00	1/2"-13
6"	DETAIL D	2.000	1.00	2.73	1.375	7.84	10.57	3.45	7.12	7.00	19.62	3/4"-10
8"						9.79	12.52	4.15	8.37	7.00	23.13	3/4"-10

TOP ENTRY BALL VALVES

Actuation Mounting - Full Port, Flanged

DIMENSIONS

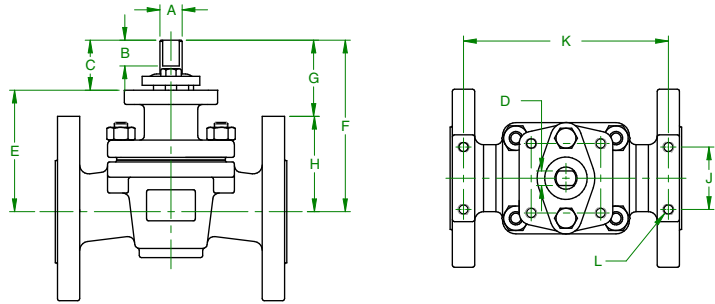

ASME CLASS 150, FULL PORT, FLANGED Dimensions in Inches

Size	Mtg Pad	A	B	C	D	E	F	G	H	J	K	L
1"	DETAIL B	0.625	0.72	1.40	0.412	3.44	4.85	2.47	2.38	1.75	6.44	5/16"-18
1.5"		0.750	0.80	1.57	0.477	4.35	4.34	1.71	2.63	1.75	8.06	5/16"-18
2"	DETAIL C	1.250	0.50	1.70	0.725	5.46	7.16	4.03	3.13	2.25	9.68	5/16"-18
3"						5.77	7.46	3.58	3.88	3.50	12.48	3/8"-16
4"	DETAIL D	2.000	1.00	2.73	1.375	8.01	10.74	5.70	5.04	4.00	15.81	7/16"-14
6"						9.51	12.24	6.08	6.16	4.00	20.25	1/2"-13
8"	DETAIL E	2.490	2.25*	5.77	NA	12.95	26.38	NA	NA	NA	NA	NA
10"	DETAIL F	3.740	3.75*	8.40	NA	17.14	25.56	NA	NA	NA	NA	NA
12"						18.94	25.54	NA	NA	NA	NA	NA

*Keyway length

ASME CLASS 300, FULL PORT, FLANGED Dimensions in Inches

Size	Mtg Pad	A	B	C	D	E	F	G	H	J	K	L
1"	DETAIL B	0.625	0.72	1.40	0.412	3.47	4.88	2.50	2.38	1.75	6.69	5/16"-18
1.5"		0.750	0.80	1.57	0.477	4.39	4.39	1.20	3.19	1.75	8.63	5/16"-18
2"	DETAIL C	1.250	0.50	1.70	0.725	5.50	7.19	3.81	3.38	2.25	9.90	5/16"-18
3"						5.88	7.57	3.23	4.25	3.50	13.68	3/8"-16
4"	DETAIL D	2.000	1.00	2.73	1.375	8.07	10.80	5.67	5.13	4.00	16.50	7/16"-14
6"						9.54	12.27	5.36	6.91	4.00	20.38	1/2"-13
8"	DETAIL E	2.490	2.25*	5.77	NA	13.10	26.38	NA	NA	NA	NA	NA
10"	DETAIL F	3.740	3.75*	8.40	NA	17.14	25.56	NA	NA	NA	NA	NA
12"						18.94	25.54	NA	NA	NA	NA	NA

*Keyway length

ASME CLASS 600, FULL PORT, FLANGED Dimensions in Inches

Size	Mtg Pad	A	B	C	D	E	F	G	H	J	K	L
1"	DETAIL B	0.750	0.80	1.57	0.477	3.95	5.52	2.96	2.56	2.38	8.75	3/8"-16
1.5"						4.79	6.36	3.11	3.25	2.75	11.06	1/2"-13
2"	DETAIL C	1.250	0.50	1.70	0.725	5.61	7.31	3.85	3.46	3.50	11.38	1/2"-13
3"						6.01	7.71	3.46	4.25	4.75	15.56	1/2"-13
4"	DETAIL D	2.000	1.00	2.73	1.375	8.19	10.92	5.42	5.50	5.50	17.75	1/2"-13
6"						9.79	12.52	5.40	7.12	7.00	23.44	3/4"-10
8"	DETAIL E	2.490	2.25*	5.77	NA	13.86	19.63	NA	NA	NA	NA	NA

*Keyway length



For additional information, submittal sheets and manuals, visit www.apollovalves.com

Customer Service (704) 841-6000

TOP ENTRY BALL VALVES

Actuation Mounting - Socket Weld & NPT

DIMENSIONS

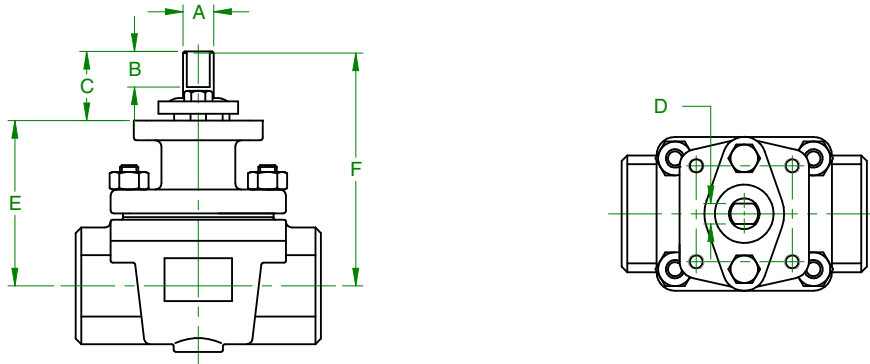

ASME CLASS 300, STANDARD PORT, SOCKET WELD & NPT Dimensions in Inches

Size	Mtg Pad	A	B	C	D	E	F
1/2"	DETAIL A	0.500	0.48	1.00	0.287	2.88	3.88
3/4"						2.88	3.88
1"						3.12	4.12
1.5"	DETAIL B	0.625	0.72	1.40	0.412	3.40	4.80
2"						4.34	5.91
3"	DETAIL C	1.250	0.50	1.70	0.725	5.16	6.86

ASME CLASS 300, FULL PORT, SOCKET WELD & NPT Dimensions in Inches

Size	Mtg Pad	A	B	C	D	E	F
1"	DETAIL B	0.625	0.72	1.40	0.412	3.40	4.80
1.5"							5.91
2"	DETAIL C	1.250	0.50	1.70	0.725	5.16	6.86

ASME CLASS 600, STANDARD PORT, SOCKET WELD & NPT Dimensions in Inches

Size	Mtg Pad	A	B	C	D	E	F	
1/2"	DETAIL B	0.625	0.72	1.40	0.412	3.41	4.82	
3/4"							4.82	
1"							4.82	
1.5"							3.68	5.25
2"							4.27	5.84

ASME CLASS 600, FULL PORT, SOCKET WELD & NPT Dimensions in Inches

Size	Mtg Pad	A	B	C	D	E	F
1"	DETAIL B	0.750	0.80	1.57	0.477	3.68	5.25
1.5"						4.27	5.84

TOP ENTRY BALL VALVES

Actuation Mounting - Butt weld

DIMENSIONS

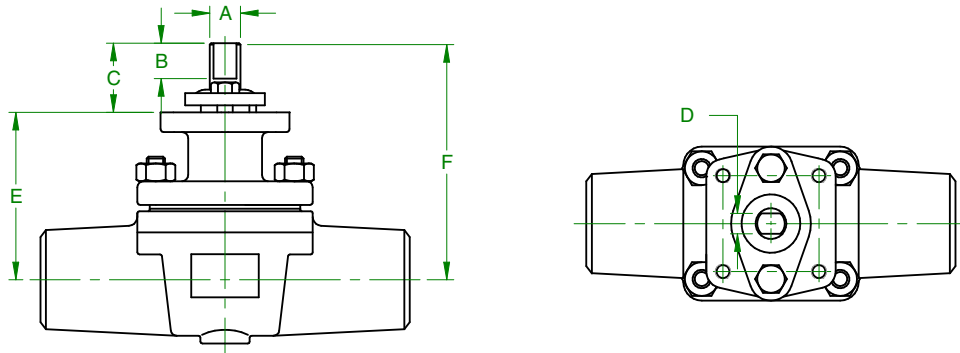

ASME CLASS 300, STANDARD, PORT BUTTWELD Dimensions in Inches

Size	Mtg Pad	A	B	C	D	E	F
1/2"	DETAIL A	0.500	0.48	1.00	0.287	2.88	3.88
3/4"						3.03	3.88
1"						3.06	4.12
1.5"	DETAIL B	0.625	0.72	1.40	0.412	3.40	4.80
2"						4.34	5.91
3"	DETAIL C	1.250	0.50	1.70	0.725	5.16	6.86
4"						5.29	6.99
6"	DETAIL D	2.000	1.00	2.73	1.375	7.59	10.32
8"						9.00	11.71

ASME CLASS 300, FULL PORT, BUTTWELD Dimensions in Inches

Size	Mtg Pad	A	B	C	D	E	F
1"	DETAIL B	0.625	0.72	1.40	0.412	3.36	4.76
1.5"						4.06	5.63
2"	CONTACT FACTORY						
3"	DETAIL C	1.250	0.50	1.70	0.725	5.87	7.57
4"	DETAIL D	2.000	1.00	2.73	1.375	8.07	10.80
6"						9.54	12.27
8"	DETAIL E	2.490	2.25*	5.77	NA	13.11	18.88

*Keyway length

TOP ENTRY BALL VALVES

Actuation Mounting - Class 600, Standard Port, Butt Weld

DIMENSIONS

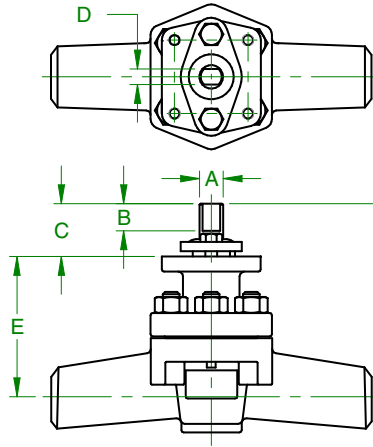

CLASS 600 BUTTWELD STANDARD PORT - SIZES 1/2" THRU 2"

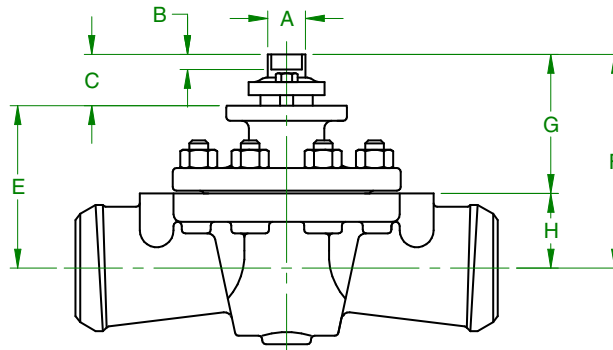
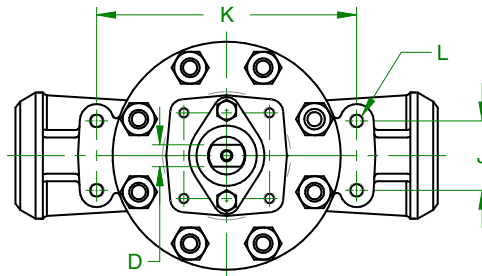

CLASS 600 BUTTWELD STANDARD PORT - SIZES 3" THRU 6"

ASME CLASS 600, STANDARD PORT, BUTTWELD Dimensions in Inches

Size	Mtg Pad	A	B	C	D	E	F	G	H	J	K	L
1/2"	DETAIL B	0.625	0.72	1.40	0.412	3.41	4.82	NA				
3/4"						3.66	5.06					
1"						3.72	5.11					
1.5"						3.92	5.48					
2"						4.73	6.27					
3"	DETAIL C	1.250	0.50	1.70	0.725	5.38	7.08	4.61	2.47	2.42	8.62	1/2"-13
4"						5.69	7.38	4.36	3.02	2.80	11.00	1/2"-13
6"	DETAIL D	2.000	1.00	2.73	1.375	7.84	10.57	6.38	4.19	4.25	15.00	3/4"-10

TOP ENTRY BALL VALVES

Standard Bonnets

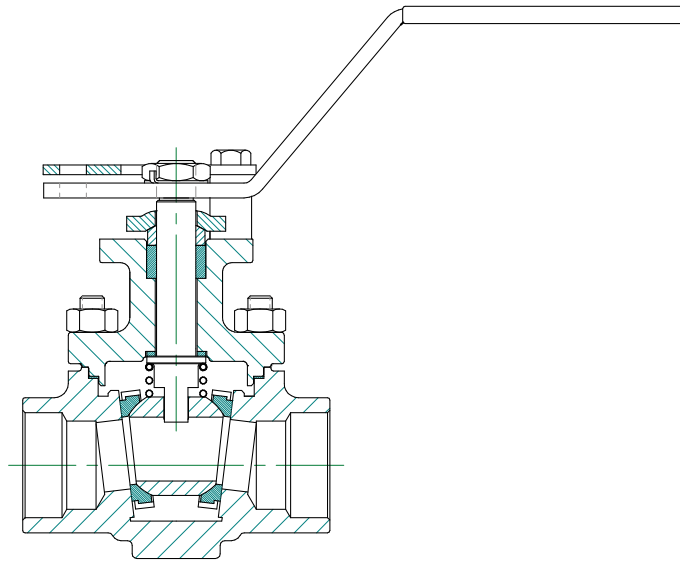

STANDARD BONNET ISO 5211 Mounting Pad

The valve's seat material "code" in the Product Numbering System determines the default stem seal material (default is either PTFE V-Rings or flexible graphite rings).

Note: To meet a wide range of application requirements, a variety of materials are offered. See options in the "How to Specify" section.

PTFE V-RING STEM SEALS

- Extremely low coefficient of friction
- Molded V-shaped rings are "spring-loaded" and self adjusting.
- Provides very good stem seal performance

Enhancement – Live Loaded Packing (add suffix to product number)

"-76" Suffix – Live loaded valve with handle or lever.

"-77" Suffix – Live loaded valve with actuator or manual gear.

Live-loaded, V-ring packing assures long maintenance-free operation by maintaining a constant packing force without over-compression. Corrosion-resistant stainless steel conical washers store compressing energy; consequently, the valve can be cycled more without stem seal adjustments

FLEXIBLE GRAPHITE RING STEM SEALS

- Die Formed Rings

Enhancement – Low Emissions

"EP" Suffix – Cup and cone graphite rings (V-shaped) are often specified for applications where fugitive emissions must be controlled.

Enhancement – Live Loaded Packing

"-76" Suffix – Live loaded valve with handle or lever.

"-77" Suffix – Live loaded valve with actuator or manual gear.

TOP ENTRY BALL VALVES

Extended Bonnets

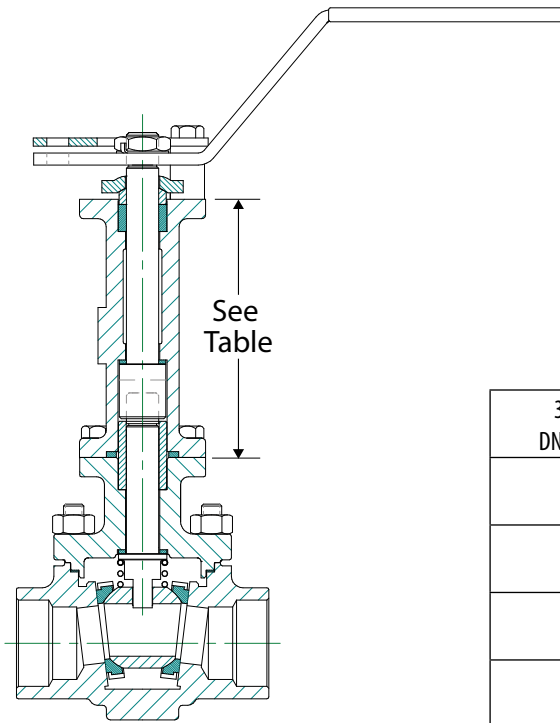

EXTENDED BONNET
(Add "-70" Suffix)

EXTENDED BONNET HEIGHT

	ASME Class 150 ASME Class 300		ASME Class 600	
	Std Port in. (mm)	Full Port in. (mm)	Std Port in. (mm)	Full Port in. (mm)
3" & Smaller DN 80 & Smaller	4" (102)	4" (102)	4" (102)	4" (102)
4" DN 100	4" (102)	6.5" (165)	4" (102)	6.5" (165)
6" DN 150	6.5" (165)	6.5" (165)	6.5" (165)	6.5" (165)
8" DN 200	6.5" (165)	10" (254)	6.5" (165)	10" (254)
10" DN 250	10" (254)	12.5" (318)		
12" DN 300	10" (254)	12.5" (318)		

ADVANTAGES:

- Extended bonnets provide excellent performance in higher temperature or semi cryogenic applications.
 - The extended bonnet design moves the stem seals further away from the process flow's temperature, and the stem seals' temperature is closer to ambient temperature.
- Extended bonnets move the packing adjustment at least 4"; therefore, installed insulation typically will not need to be disturbed to adjust the stem packing.
 - If and when stem leakage occurs, it can be immediately observed and corrective action taken without insulation removal.
- A valuable feature of the Extended Bonnet is that it is field retrofitable.
 - In addition to being able to order valves with several bonnet styles direct from the factory, pre-assembled kits are available with the stem, bonnet, packing, gland, plate and nuts assembled together and properly torqued for dependable performance. Contact your local Apollo Representative for kit part numbers for any specific valve or application.

TOP ENTRY BALL VALVES

Double Packed Bonnets

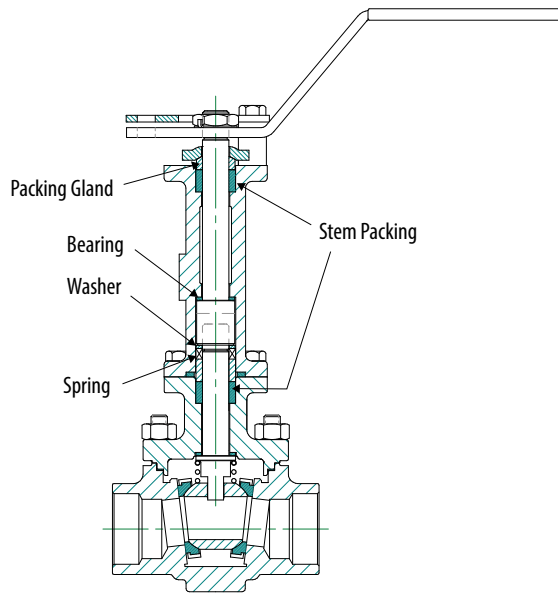

**DOUBLE PACKED
BONNET**
(Add "-90" Suffix)

Apollo recommends also specifying live-loading with the "-90" option.

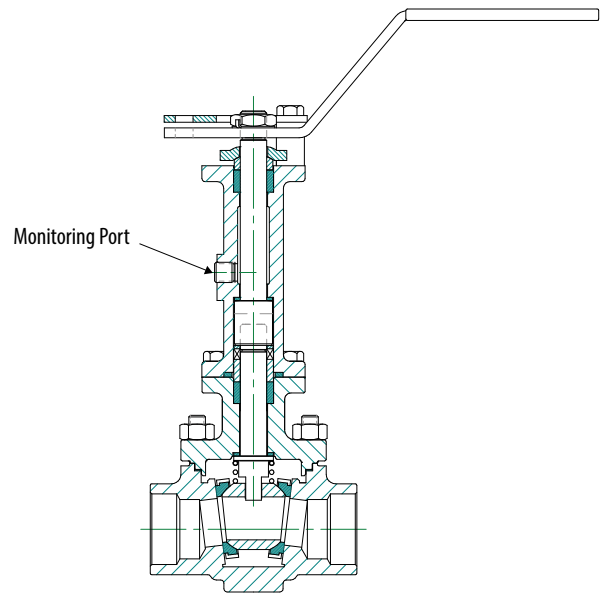

**DOUBLE PACKED
BONNET WITH PORT**
(Add "-9P" Suffix)

Apollo recommends also specifying live-loading with the "-9P" option.

The standard Apollo Top Entry Valve bonnet with PTFE V-Rings or Graphite V-Rings ("-EP") provide exceptional fugitive emission performance. See *Standard Bonnet Configuration*.

In conditions where double packed shaft sealing systems are required, Apollo also offers the "-90" and "-9P" sealing systems.

Apollo's Double Packed Bonnets ("-90" and "-9P"):

- Designed and tested to keep fugitive emissions below 100 parts per million volume (ppmv) in your application for tens of thousands of cycles.
- Installs easily on existing valves or can be purchased with new valves.
- Helps seal your process to conserve valuable process fluid while protecting the environment against the emission of hazardous or polluting fluids.
- Longer life and improved reliability of Apollo Double Packed Bonnet systems reduce maintenance cost and downtime.