

611F

Class 125, Outside Screw & Yoke,
Gate Valve

SUBMITTAL SHEET

"Apollo" Valves



Job Name:	
Job Location:	
Engineer:	
Contractor:	
Tag:	
PO#:	
Rep:	
Wholesale Dist.:	

DESCRIPTION

The Apollo International™ Model 611F Flanged Cast Iron Gate Valve provides full flow capabilities. The Model 611F Gate Valve can be reliably installed in plumbing and heating systems (or building service piping).

FEATURES

- Compatible with ANSI 125# & 150# Flanges
- Full Port
- Bronze Mounted Seat Rings/Trim
- Solid Wedge
- Adjustable Graphite Stem Packing
- Outside Screw & Yoke
- Flanged Connection
- Bolted Bonnet
- Rugged Iron Hand Wheel
- Back Seat Protection

PERFORMANCE RATING

- Saturated Steam:
125 psi (8.6 Bar) at 353°F (2"-12")
100 psi (6.9 Bar) at 338°F (14"-24")
- Cold Working Pressure:
200 psi (13.8 Bar) at 100°F (2"-12")
150 psi (10.3 Bar) at 100°F (14"-24")
- Temperature Range: -20°F to 406°F Max

APPROVALS

- MSS SP-70 - Gray Iron Gate Valves Flanged and Threaded - Type 1
- ASME B16.10 - Face-to-Face and End-to-End Dimensions of Valves

STANDARD MATERIALS LIST

1	BODY	Cast Iron (ASTM A126 CL B)
2	SEAT RINGS	Cast Bronze (ASTM B62)
3	WEDGE FACE RINGS	Cast Bronze (ASTM B62)
4	WEDGE	Cast Iron (ASTM A126 CL B)
5	STEM	Brass (ASTM B16)
6	BODY GASKET	Graphite (Asbestos Free)
7	BOLTS	Carbon Steel (ASTM A307 B)
8	NUTS	Carbon Steel (ASTM A307 B)
9	BONNET	Cast Iron (ASTM A126 CL B)
10	BACK SEAT BUSHING	Cast Bronze (ASTM B584)
11	PACKING	Graphite (Asbestos Free)
12	PACKING GLAND	Cast Bronze (ASTM B584)
13	GLAND FOLLOWER BOLTS	Carbon Steel (ASTM A307 B)
14	GLAND FOLLOWER NUTS	Carbon Steel (ASTM A307 B)
15	GLAND FOLLOWER	Ductile Iron (ASTM A536 65-45-12)
16	YOKE BUSHING	Cast Bronze (ASTM B62)
17	YOKE BUSHING NUT	Cast Iron (ASTM A126 CL B)
18	SCREW	Carbon Steel (ASTM A307 B)
19	HANDWHEEL	Cast Iron (ASTM A126 CL B)
20	NAMEPLATE	Aluminum
21	HANDWHEEL NUT	Ductile Iron (ASTM A536 65-45-12)
22	YOKE	Cast Iron (ASTM A126 CL B)

PART NUMBER MATRIX

Size (in.)	Part Number
2"	6GA118B1
2-1/2"	6GA119B1
3"	6GA110B1
4"	6GA11AB1
5"	6GA11BB1
6"	6GA11CB1
8"	6GA11EB1
10"	6GA11GB1
12"	6GA11HB1
14"	6GA11JB1
16"	6GA11KB1
18"	6GA11MB1
20"	6GA11NB1
24"	6GA11PB1

* The lead free version of this valve is a running change. Contact customer support for availability.

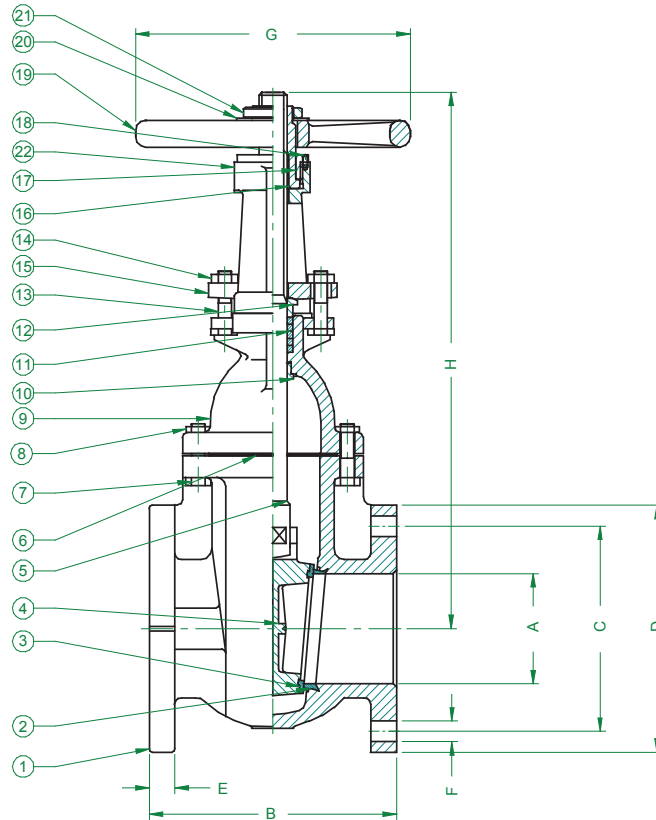

Size (in.)	Dimensions (in.)								Wt. (lbs.)	Cv (Typ)
	A	B	C	D	E	F	G	H (Open)		
2"	2.00	7.00	4.75	6.00	0.62	0.75	7	14.96	38	328
2.5"	2.50	7.50	5.50	7.00	0.69	0.75	7	16.93	51	482
3"	3.00	8.00	6.00	7.50	0.75	0.75	8	19.09	62	744
4"	4.00	9.00	7.50	9.00	0.94	0.75	10	24.21	110	1316
5"	5.00	10.00	8.50	10.00	0.94	0.88	12	27.56	154	2130
6"	6.00	10.50	9.50	11.00	1.00	0.88	12	32.87	203	3176
8"	8.00	11.50	11.75	13.50	1.12	0.88	14	39.76	284	5692
10"	10.00	13.00	14.25	16.00	1.19	1.00	16	48.03	459	8972
12"	12.00	14.00	17.00	19.00	1.25	1.00	18	56.50	637	13352
14"	14.00	15.00	18.75	20.98	1.38	1.14	20	65.16	966	16278
16"	16.00	16.00	21.25	23.50	1.44	1.14	22	71.85	1135	21564
18"	18.00	17.00	22.75	25.00	1.56	1.26	24	79.53	1753	28716
20"	20.00	18.00	25.00	27.52	1.69	1.26	25	90.16	2238	35762
24"	24.00	20.00	29.50	32.01	1.88	1.38	30	132.28	3197	52166

Cv = GPM @1 psi pressure drop, 60°F water

*Cv values are estimates only